

# RCI YG80 Door Lock

## Electronic Door Locking Solution



This high-strength lock is designed for securing gates, roll-up doors, shipping containers, and any other large door or entryway. This impressive locking solution offers the ability to integrate into an access control system. Fully monitored, weatherproof, and user configurable, the RCI YG80 is the perfect indoor and outdoor locking solution.

### Features

- With an 18 mm diameter stainless steel bolt pin and reinforced strike design, the YG80 has a holding force of 11,240 lbs.
- Concealed mounting bolts under the lock's cover, which cannot be removed without triggering the tamper detection monitor.
- Completely weatherproof. Ingress protection to IP67.
- Aluminum lock body for excellent corrosion resistance.
- Built-in heater for continued functionality in colder climates, the YG80 can handle any environment it is placed in.
- Complete monitoring capabilities.
- Provides a range of output signals - bolt locked and unlocked position, door position, and tamper detection.
- Low current consumption.
- With the heater disabled, the YG80 will draw as little as 50 mA in standby, and only 1,000 mA in operation at 12VDC. (Heater @24VDC only).
- Integrated access control system capabilities.
- Selectable fail safe / fail secure modes, three user selectable control methods, and multiple attempts to lock or unlock, ensures that the YG80 is ready for a wide range of application requirements.
- A symmetrical design means the YG80 can be installed both horizontally and vertically, in indoor and outdoor environments.
- The included three meter flying cable ensures easy connection for all the monitoring, control and the 12-24VDC power supply.

## Dimensions

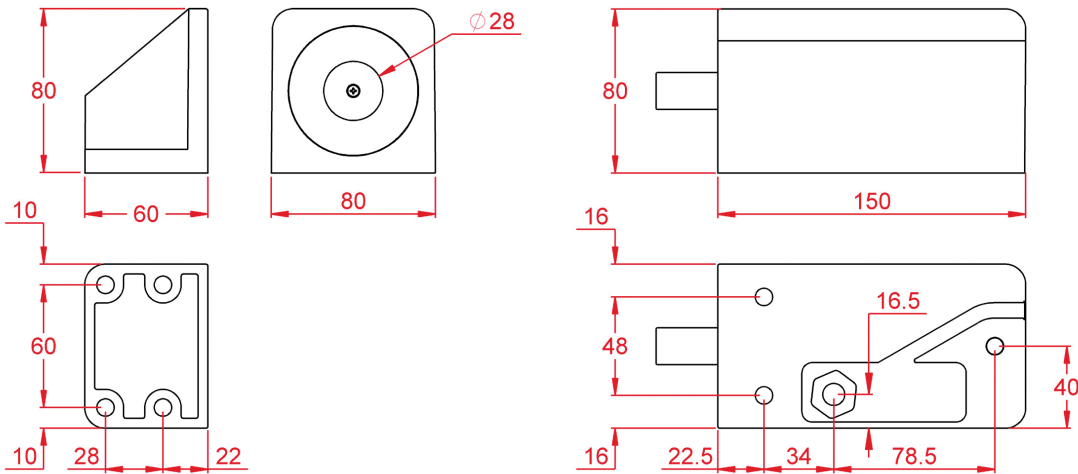

Drawings are not to scale. Dimensions are in millimetres (mm).

## Specifications

Door gap	15 mm maximum
Static strength	11,240 lbs.
Dynamic strength	148 ft.-lbs.
Endurance	300,000 Cycles
Voltage at lock	12-24VDC +/- 15%
Auto relock	Will attempt to lock or unlock 3 times if obstructed during operation.
Initial power up time	25 seconds, only after power has been removed for an extended period.
Current usage	Standby Current: 50mA@12V; 40mA@24V; 1.6A@24V with heater on. Maximum Current: 1.0A@12V; 0.5A @24V; 2.0A@24V with heater on.
Monitor switch ratings	24VDC, 0.25A
Certifications and listings	<p><b>Environment:</b> IP 67 Rating – suitable for indoor and outdoor use. Cold, -35°C EN 60068-2-1:2007 Dry Heat, +70°C EN 60068-2-2:2007 Corrosion, 240 Hours Salt Spray EN 1670:2007, Grade 4</p> <p><b>FCC:</b> Title 47, Part 15, Subparts A &amp; B – Class B Device</p> <p><b>ISED (IC):</b> ICES-003 – Class B Device</p>

© dormakaba 2019 Information on this sheet is intended for general use only. dormakaba reserves the right to alter designs and specifications without notice or obligation.